



SDconnect

More Mobility - More Diagnosis

Mercedes-Benz



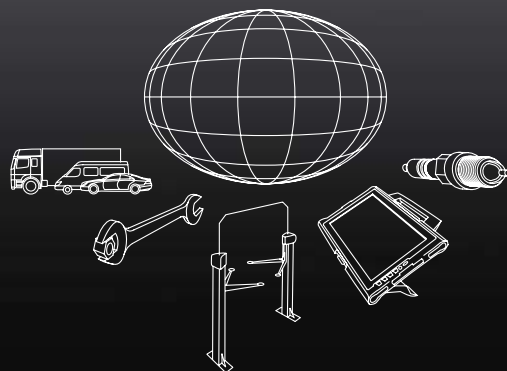

<http://aftersales.mercedes-benz.com>

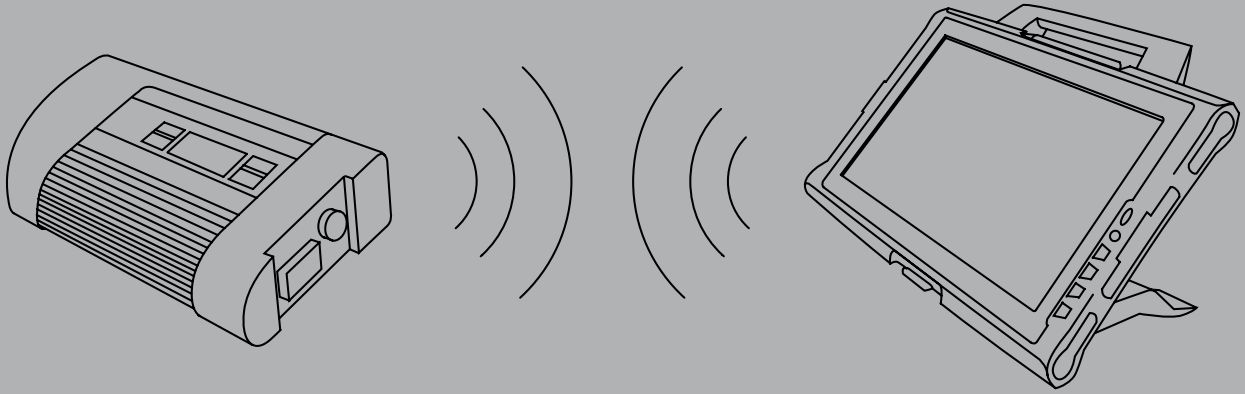

SDconnect

Transfer diagnostic data wirelessly

SDconnect

More Mobility – More Diagnosis



Wireless Data Transfer

A new technology for wireless vehicle diagnosis – that's SDconnect. This multiplexer transfers fault detection data over the WLAN to Star Diagnosis compact⁴. In workshop mode, the data is transmitted via an access point into the workshop's computer network. SDconnect has an option to transmit data directly to the diagnostic unit in road mode – even outside the workshop environs. In this way, the mechanic can move freely and unhindered when diagnosing.

Advanced Diagnosis Options

The new Star Diagnosis CANtool built into SDconnect offers users new ways of troubleshooting. The tool aids the monitoring and recording of data flows in the vehicle. This enables the diagnosis technician to make even more accurate inspections and to determine faults more precisely. Bus wake-up and bus keepawake events can be detected with SDconnect. This function is called up in DAS. SDscan, the separate expert software, offers even more complex CAN diagnostic functions. The prerequisite for using this software is the relevant technical know-how. We will be happy to advise you in this regard. Additional information may be found at <http://aftersales.mercedes-benz.com>

Reliable Combination

The service technician controls SDconnect via Star Diagnosis compact⁴. The central software SDnetControl on the diagnostic system combines all the important functions for operating the wireless multiplexer, i.e. information, setting and switching the connection, selecting the multiplexer, and self-diagnosis. In addition, SDconnect offers a display, four control buttons and two LED displays for information on the current operating condition. An acoustic signal warns the mechanic if he leaves the radio range of the workshop with the mobile unit. The unit is also equipped with an improved self-diagnosis feature. This enables the mechanic to better detect possible malfunctions of the multiplexer.



Simplicity of Use

SDconnect is easy to operate thanks to its compact dimensions of 22 x 16 x 5 cm. The wireless connection to the diagnostic unit affords maximum mobility. SDconnect does not require time-consuming familiarization. The configuration wizard SDnetAssist guides the user through setting up Star Diagnosis compact⁴ and SDconnect for wireless operation. Operation without a wireless connection is also possible. The units are pre-configured for non-wireless operation and can be operated at any time via the connection cable included in the scope of delivery.

Product information

Hardware

- SDconnect works with Star Diagnosis compact⁴ and Star Diagnosis compact³ w
- Cast aluminum housing. Elastomer buffers protect all edges against impacts and shocks
- Jack for connecting cable (Ethernet cross-link CAT 5/RJ45) with strain-relief clamp
- Vehicle cable connection with „push/pull“ mechanism
- Slot for WLAN card for wireless connection to the Star Diagnosis system with or without access point infrastructure
- Integrated compartment for rechargeable batteries (6 AA 1.20 volt batteries) to maintain voltage when changing vehicles. The unit is charged through the OBD socket on the vehicle, an external voltage supply may also be connected via the separate test adapter.
- Protected against dust and splash water (IP protection class 54)
- Number clip to identify unit
- Weight: 1.42 kilograms
- Dimensions: 220 x 160 x 50 millimeters
- The following components are required to use the Star Diagnosis CANtool: electrical connection kit and adapter cable for potential distributor (new model series)

Software

- SDconnect software for administration, configuration and self-diagnosis
- Star Diagnosis CANtool: The standard scope is integrated in DAS and can be called up from there. The SDscan expert software can be run as a separate application, and presumes a relevant, trained professional knowledge base

Update service

- Regular program and data updates
- Provided on DVD
- Up-to-date add-ons by online update from the Internet



Permanent help and support

- The Star Diagnosis User Help Desk offers support of both software and hardware
- Qualified advice in several languages: German, English, French, Spanish, Italian, and Japanese

Notes on wireless network operation

The use of wireless communication networks and the use of systems in these networks must meet the appropriate rules and regulations of your country. More information can be obtained from the relevant authorities. Make sure you know the country-specific conditions for operation of wireless communication networks in your market. If necessary, remove a non-permissible wireless card from SDconnect. Information about the system can be found in the documentation enclosed with the Star Diagnosis delivery package and the documents supplied in the information system INFO. An additional wireless card is required for the wireless network in some markets and for certain systems. You can find out from your market representative or in the After-Sales Portal whether your Star Diagnosis system is suitable for wireless operation in your market at <http://aftersales.mercedes-benz.com>

Your personal contact

- Mercedes-Benz and smart operations must contact their national representation for orders
- Independent operators should contact a Mercedes-Benz or smart operation or their national representation

Daimler AG

GSP/OI

D-70546 Stuttgart

<http://aftersales.mercedes-benz.com>